

ECG HOLTER SYSTEMS - DEVELOPMENT AND PERSPECTIVES

**Chavdar Levkov, Rositsa Arnaudova, Stephan Dunev, Hovadim Bakardjian,
Grigor Neshev**

Signa Cor Laboratory, ul. Yastrebec 25 B, Sofia 1680, Bulgaria, phone: +359 2 858 2341,
info@signacor.com , www.signacor.com

A company profile of a very small hi-tech company is presented along with the description of their successful product 'Ambulatory digital ECG recording and analyzing system (Holter method)'. Future trends of the field are discussed. Some observation in creating and developing a successful small hi-tech company are presented.

Keywords: electrocardiography, digital filters, ECG, company profile

1. INTRODUCTION

Please comply with these requirements:

SignaCor is a very small company and has been founded in 1991. There was a single goal: development, production and marketing of an Electrocardiographic (ECG) digital ambulatory recording system – so called Holter ECG. Four people were engaged in this project which took almost 1,5 years.

ECG Holter means briefly 24 hours or more of recording and analysing of ECG signal (several channels). This is a standard method and is unique, since it is the only method where rare disturbances of cardiac rhythm can be accessed and diagnosed. The market situation these days were as follows: A complete Holter system costs between 20÷60 000 USD. Most of the systems were analogue with 2 channels. There were only 2 or 3 digital systems commercially available on the market (two American and one German companies). Neither of these systems was capable to make a continuous recording of 24 hours period (full disclosure) but the digital era has come. These days the static RAM was almost the only solution for a large battery powered memory – and it was expensive. To mention our first recorder was with 1 Mbytes of RAM – 8 chips 8×128 Kbytes and only the chips in the memory module costs more than 300 USD.

1.1 Hardware

A standard microprocessor system is used (see figure) HD 6303 from Hitachi was chosen with 1,8 MHz clock. An external module with 4Mbytes static RAM is used. The input is a low noise 4-channel amplifier with a body potential driving [1]. The electrode to skin impedances are also measured since from these impedances depends very much the noise level at the amplifiers input. There is a serial communication module with galvanic isolation due to the requirements for patient safety.

1.2 Signal Processing

The input signals are amplified and digitised at rate of 200 Hz. Three digital filters procedures are made – drift filter, 50 Hz rejection filter [2] and smoothing. A several seconds of incoming signal are saved in a temporary buffer for further processing.

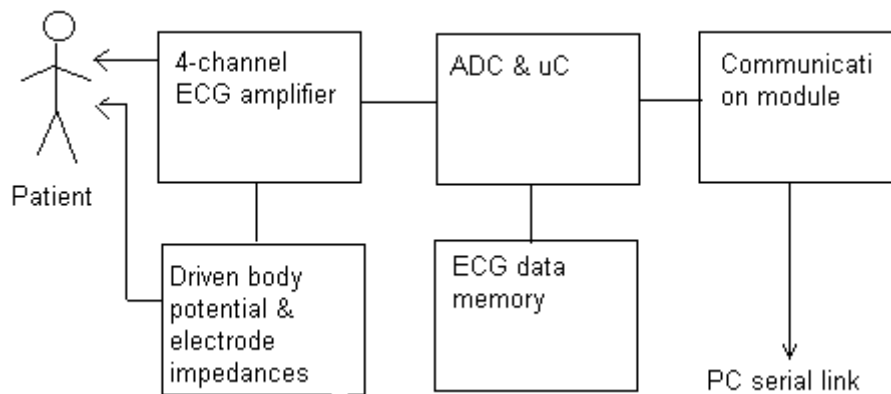

ADC and digital signal processing's must be performed simultaneously in different buffers. To solve this problem, a real-time multitask software was developed. Up to 10 tasks are performed at the time of maximal processor load. After the filtration follow the recognition of ECG signal waveforms [4] and measurement of their parameters. The recognition system is adaptive – the first several minutes of the recording, the processor was busy to evaluate and capture the individual patient's features of the ECG. During the recording this adaptation also took place to follow the irregular changes of the ECG signal. (Abnormal and physiological changes are very common during the 24 hours period). At the end of the digital processing a classification process is performed, which classifies different heartbeats according to accepted rules. If the current ECG episode is abnormal, a record in the RAM is made. Two ECG signal compression techniques are used – approximation compression with insignificant loss of information and algebraic lossless Huffman's like compression. All the firmware was written on FORTH language and about 30 % on assembler (filtration & multitask).

The memory content is transferred through the serial channel to the personal computer (PC). On the computer, a sophisticated data management, display and analyses software exists. As it can be seen, all these features were performed by a simple 8 bit 1,8 MHz microprocessor in real-time.

1.3 Challenges

The hardware demands are not so easy to fulfil: Low power consumption – at least 24 hours with acceptable power source; There must be absolutely reliable watchdog control since the period of procedure is quite long and the patient is free moving and working environment can not be controlled; Small size and weight are necessary; The apparatus must has to be rugged and withstand sweating, coffee spilling etc.; The patient should not be able to open it, to switch it on and off and see how the machine works!; The information should be safe even after 30 s of removing the batteries.

The software problems are even more complicated. The signal is very noisy since it comes from a free moving patient. The amplitude is from 10 μV up to 6÷8 mV. There is a substantial base line drift due to electrode potential instability, 50 Hz power-line interference and muscle tremor voltages with spectral densities

overlapping the spectrum of the ECG signal. In this environment there should be almost 99,99 % reliable recognition of ECG waveforms. For 24 hours there is approximately 100 000 heartbeats but very often only 10÷70 beats are abnormal. These beats should not be missed! From the other side there should not be too much false positive recognition, because the statistic becomes unreliable and the physician is loaded with additional labour to remove the false recognised beats.

2. CURRENT STATE AND PERSPECTIVES

2.1 Technology

The modern Holter recorders are digital. Flash memory was a breakthrough and using some kind of flash card is obligatory. The data memory is practically unlimited and the duration of the procedure is limited by the capacity of the power source. Some of the commercial recorders do not use any signal compression. Whether this is an advantage is not so clear. The size of the patient file becomes huge (up to 100 Mbytes) and data base requirements and data exchange between different medical levels is difficult and not practical. Internet applications are at the very beginning and the so-called telemedicine is on the schedule. The number of channels is increased and the limit is a recorder that saves 12 standard ECG waveforms. There are not significant improvements in Holter method from medical point of view. Some perspective improvements are the recording or extracting the breathing signal to be used in sleep apnoea investigations. The Q-T recognition should also be mentioned but the reliability of recognition is still questionable. The ECG waveforms recognition algorithms are continually improved but the time of 100 % automatic Holter analysis is still in the future. The P-wave recognition for rhythm analysis is still very unreliable in the presence of significant noise, which is the case of the Holter signal. The current clinical accepted method is that the physician should review the record with the help of the automatic detection, but visual confirmation or rejections of the automatic decisions are obligatory.

Where is now SignaCor? Generally speaking the current model is almost the same as 1991 model! It is smaller, 4-channel continuous record, up to 72 hours with fast 21 MHz processor with one AA size Ni-Mh accumulator. May be the biggest improvement is the ability to reconstruct the 12 standard ECG leads [3] which makes our new model practically 12-channel electrocardiograph.

2.2 Markets

The Holter system is a standard electromedical apparatus and there are too many competitors. We have information of more than 25 commercial producers and possible there are still more. The price level of a system is between 3000÷15 000 USD. Where we are? On the domestic market we are the leaders, possibly more than 50 % market share. We have a small export in neighbouring countries. The company is very small but we are doing all the tasks needed for medium-size Company to reduce expenses. The production is distributed to different subcontractors - the rule is if there is a capable subcontractor which can do the job with needed quality we are using him. The quality control of our production is 'hand-made' – every piece of

equipment is tested and examined very carefully. From the beginning of 1991 we are giving 2 years full guarantee period and the maintenance service is also performed by us.

2.3 Conclusion: Some thoughts about small Hi-tech Company

From the scientific point of view it is difficult to generate know-how in a small commercial company without any external non-commercial funding. When a new hi-tech small firm is founded the know-how knowledge must be already available or at least 70÷80 % of it. Where the knowledge is created? It depends and there are no rules – but someone else should pay for it. This can be a spring-off of a big company created by unrecognised smart boys; or university, or some state or private fund investment. Further, for the small firm, it is not difficult to be in a step with the technological improvements. New ICs and software are always a pressure – but manageable. We have changed 3 times the commercial models in our 15 years period. But this is a kind of maintenance this is not know-how.

Here are some important moments:

a. Real know-how.

There are no rules how to create it.

b. Developing market.

Either technologically or politically developing market must exist. The developing market means that the cost of the design will be low and the market is hungry. There are not or very few limitations from the state, from patents barrages etc. The standards are still not created and the engineer can use his creativeness and imagination to put on the market really outstanding products. The moment the market reaches steady state the time for a small stand-alone hi-tech company has gone. Now comes the time of the bigger companies, standards, quality management's systems and etc. In this situation the initial development to fulfil all the market requirements and limitations becomes very expensive. One very important thing is that there are regulations not only what your product must look like but also regulations to your customers – they are not free to buy anything. They are inspired to buy only products with some kind of certification. This is not bad, this is self-protection of the society from frauds, but in this way many good, reliable and cheap products are lost. What we mean – you can still create a new product but do not try to produce and sell it by yourself. Try to sell it to a bigger company, she will do the rest of the job and if you have a chance, the product will be placed on the market.

2. REFERENCES

[1] Levkov, Ch. *Amplification of Biosignals by Body Potential Driving*. Med. & Biol. Eng. & Comput., 20, 248-250, 1982.

[2] Levkov, Ch., Michov, G., Ivanov, R., Daskalov, I. *Subtraction of 50 Hz Interference from the Electrocardiogram*. Med. & Biol. Eng. & Comput., 22, 371-373, 1984.

[3] Levkov, Ch. *Orthogonal Electrocardiogram Derived from the Limb and Chest Electrodes of the Conventional 12-lead System*. Med. & Biol. Eng. & Comput., 25, 155-164, 1987.

[4] Levkov, Ch. *A Quantitative Estimation of Proximity between ECG Waveforms*. In 'Advances in Biomedical Measurement', Plenum Press, London, 1988.